

INSTALLATION INSTRUCTIONS

DESCRIPTION: GYTR Billet Clutch Cover
PART NUMBER: BHR-E54E0-V0
MODEL: 2023+ YZ450F

GYTR
GENUINE YAMAHA TECHNOLOGY RACING
PERFORMANCE PRODUCTS

YAMAHA
GENUINE
Parts & Accessories

⚠ WARNING

Please read and understand these instructions completely before installation to avoid possible injury, or damage to the accessory or vehicle.

IMPORTANT: YZ models are for closed-course competition only regardless of modification.

NOTICE:

Installation of this kit requires a torque wrench and should be performed by an authorized Yamaha dealer or a qualified mechanic.

WARRANTY INFORMATION:

In the United States, see your Yamaha dealer for a copy of the Yamaha Genuine Parts and Accessories Limited Warranty.

DEALER OR INSTALLER:

These instructions contain important information for future reference and *must* be given to the customer.

PARTS LIST:

No.	Part Number	Description	Qty
--	BHR-E54E0-V0	GYTR Billet Clutch Cover	--
①		Clutch Cover	1

* Part supplied with kit only and not available separately.

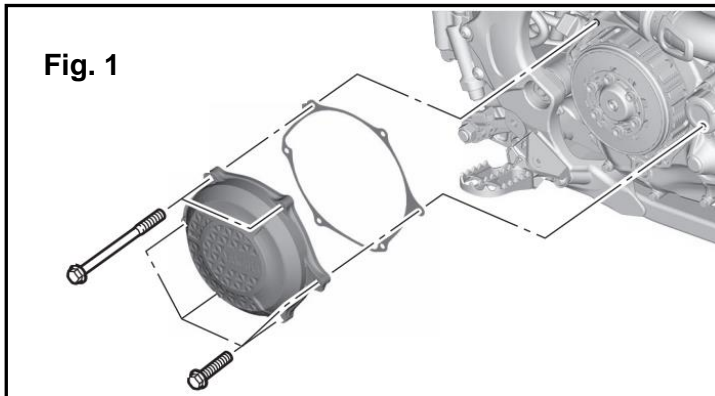
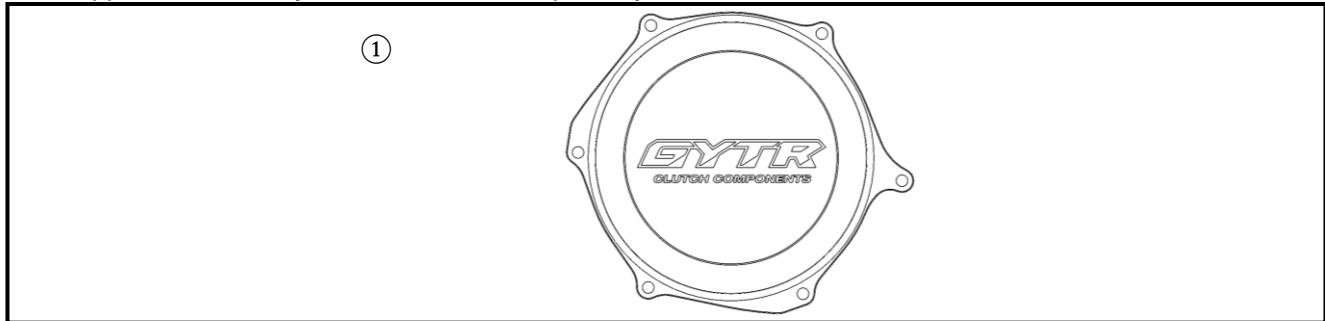

Fig. 1

MAINTENANCE:

Periodically check all clutch cover bolts for tightness and re-torque as necessary.

CARE AND CLEANING:

Wash the exterior of the clutch cover with a mild soap and water solution and soft cloth.

CUSTOMER SERVICE:

For further information see your Yamaha dealer.
ESTIMATED TIME TO INSTALL: 0.1 HRS.

PREPARATION:

- Stand the motorcycle on a secure and level surface.
- Drain the oil from the engine.
- Alternately, lean the motorcycle on its left side, and ensure that any oil lost during installation is replaced.
- Clean all mounting surfaces before beginning installation.

INSTALLATION:

1. Remove the stock clutch cover referencing the Yamaha Owner's Service Manual. Check gasket for damage or separation, do not reuse if damaged.
2. Install the GYTR Clutch Cover ① and gasket using the stock hardware. (Fig. 1) Tighten and torque clutch cover bolts in stages and in a crisscross pattern to 10 Nm (1.0 m-kgf, 7.4 ft-lbf).